

Multi-Point Level Switch Series LC30/LCM11

Level Transmitter Series LE70/LEM70



Series LC30/LCM11 is a Multi-Point Level Switch for float with magnetic field

Series LE70/LEM70 is a Level Transmitter with 0...4-20 mA analog output

Working pressure manufacturing according to PED 97/23/CE (Lloyd's Register Certificate N° 031)

The signal is based on the resistance of a series of reed switches which are controlled by the magnetic field of a float travelling on a guide.

(On request HART, PROFIBUS, FIELDBUS protocol)

The standard installation is vertical over the tank with a flanged or thread connection. Is available in the corrosion resistant materials of EN 1.4401 (SS 316L), PVC, PVDF, PTFE or PP. It is designed for:

- Food products
- High & Low Level alarms
- Process tanks
- Stop/Start of pumps for level control
- Control of level in tankers/ships
- Level control in tanks for chemical dosing
- Tank farms with centralised monitoring
- Control of tanks (available capacity & level alarms)
- Inventory control and re-order alarms of process materials
- Monitoring & control of auxiliary tanks in power plants, chemical plants, textile industry etc.
- Construction with Explosion Proof enclosure, on request

Measurement Principle

LC30/LCM11

The float activates a bi-stable reed switch by a magnet built into the float.

LE70/LEM70

A float containing a magnet will switch a series of resistors/reed switches to provide a relationship between electrical resistance and liquid level.



Level switch

LC30, LC31, LCM11, LCM12

Operation

Inside the guide tube, bi-stable reed switches are mounted at the alarm/control points. As the float passes the position where a reed switch is located, the magnetic field from the float activates the switch to leave it set indicating whether the float is above or below the position of the switch.

The maximum number of alarm or control points is 9 (for LC30/LC31 Series).

The LC30 has two types of contacts for level indication, RSC and Bi-Stable RBC. The difference is in the status of the contact once the float has passed the contact.

This system provides an indication of when the level is at the same position as the reed switch but will not provide an indication of the level away from this point. That is, it provides an indication of actual level but not high or low level.

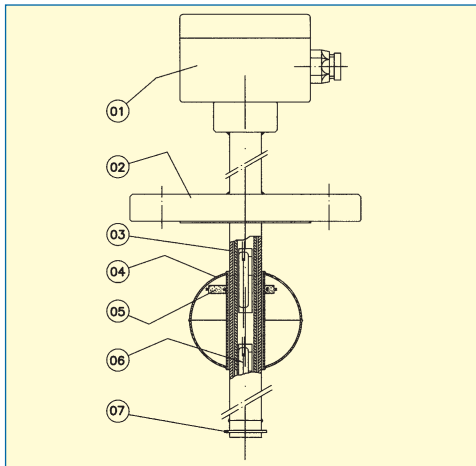

Technical Data

- Installation: Vertical
- Connection:
 - LC30, LCM12: Flange DN40 PN16 EN 1092-1
On request (DN25, DN100 & DN150, ASA, JIS)
 - LC31, LCM11: Thread 1 1/2" G (BSP/NPT)
On request 1", 2" NPT, Sanitary
- Maximum Length:
 - LC30 ... 31
 - 6 m in EN 1.4404 (SS 316L)
 - 2,5 m in PVC, PTFE, PP
 - 6 m in PVC, PTFE, PP with internals in EN 1.4404 (SS 316L)
 - LCM11 ... 12
 - 2 m in EN 1.4404 (SS 316L)
 - 2 m in PVC, PP with internals in EN 1.4404 (SS 316L)
- Diameter of float: According to table on page 4
- Liquid density: From 0.45 to 3 kg/l
- Liquid viscosity: Maximum 1500 mm² · s⁻¹
- Precision: ± 2 mm
- Hysteresis: ± 4 mm
- Materials: EN 1.4404 (SS 316L), PVC, PTFE
- Working pressure manufacturing according to PED 97/23/CE (Lloyd's Register Certificate N° 031)
- Pressure:
 - PN16 for EN 1.4404 (SS 316L) and PVC or PTFE with internals in EN 1.4404 (SS 316L)
 - PN10 for all PVC or PTFE...
- Liquid Temp.:
 - 20°C to...+150°C EN 1.4404 (SS 316L), PTFE
 - 0°C to...+50°C PVC
 - 10°C to...+90°C PP
- Ambient Temp.:
 - 20°C to...+60°C EN 1.4401 (SS 316L), PTFE
 - 10°C to...+60°C PP
 - 0°C to...+50°C PVC
- Contacts:
 - Reed 0.5A 250 VA 60 WVA
 - (Maximum 9 with minimum separation of 70 mm, available for LC30/LC31 Series only)

Types of Reed Switches

Series RSC

The RSC is a reed switch without "memory". It is only activated in presence of the magnetic field of the float. If the float moves away for the position of the switch, the switch returns to it's non-active position, which is the same for the float being above or below the switch.

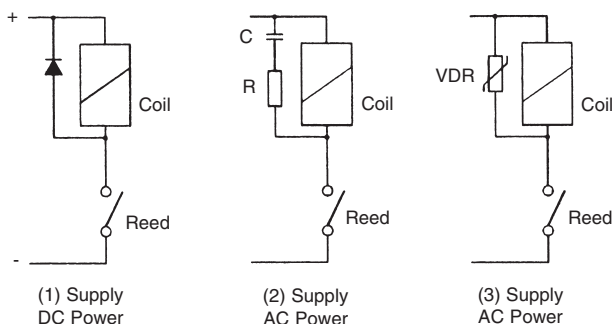

Series BI-STABLE RBC

The bi-stable RBC reed switch remains in it's switched position after the float has passed. It will remain in one position when the float is below and remains in the opposite position while the float is above the reed switch. This provides a High/Low indication but will not indicate the exact position of the level.

When using inductive loads, such as relays or electro-valve coils, surge arresters should be installed to protect the reed contacts. With a DC supply, a diode should be used.

For an AC supply, an RC circuit can be used as shown, although a varistor (VDR) is better and is easier to select the right value. The VDR should have a breakdown voltage greater than 1.5 times the **rms** voltage.

The standard varistor ratings specify the **rms** working voltage for the varistor, for example a S05K25 variator will have for 25 Vrms of working voltage and will have a breakdown voltage of 39 V at 1mA.

Transmitters

LE70, LE71,

LEM70, LEM71

Operation

A tube/guide, of length equal to the measuring range, contains a chain of reed switches with resistors. A float containing a magnet is mounted around the guide.

The variations in level displace the float so that the magnetic field operates reed switches to alter the overall resistance of the chain of resistors, providing a value proportional to the fluid level.

The overall resistance is converted electronically to a 0/4-20 mA signal.

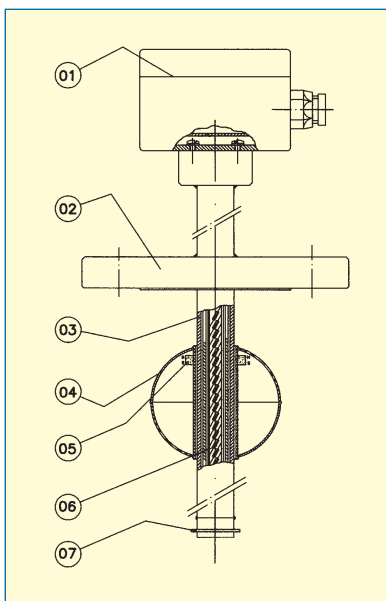

Technical Data

- Installation: Vertical
- Connections:
 - LE70, LEM70: Flange DN40 PN16, EN 1092-1
On request ASA
 - LE71, LEM71: Thread 1 1/2" G BSP-M
On request, NPT, sanitary
- Maximum Range:
 - LE70 ... 71
 - 6 m in EN 1.4404 (SS 316L)
 - 2,5 m in PVC, PTFE, PP
 - 6 m in PVC, PTFE, PP with internals in EN 1.4404 (SS 316L)
 - LEM70 ... 71
 - 2 m in EN 1.4404 (SS 316L)
 - 2 m in PVC, PP with internals in EN 1.4404 (SS 316L)
- Diameter of float: According to table on page 4
- Liquid density: From 0.45 to 3 kg/l
- Liquid viscosity: Up to 1500 cSt (1500 mm² · s⁻¹)
- Accuracy: 10 mm (one step)
- Hysteresis: 10 mm (one step)
- Materials: EN 1.4404 (SS 316L)
On request PTFE, PVC and others
- Working pressure manufacturing according to PED 97/23/CE (Lloyd's Register Certificate N° 031)
- Pressure: PN16 (on request up to PN100)
- Liquid Temp.:
 - 20°C to...+150°C in EN 1.4404 (SS 316L) & PTFE
 - 0°C to...+90°C in PP
 - 0°C to...+50°C in PVC
- Ambient Temp.:
 - 20°C to...+ 60°C in EN 1.4404 & PTFE
 - 10°C to...+60°C en PP
 - 0°C to...+50°C en PVC
- Output signal: 0...4-20 mA, 0-5V, 0-10V
(On request HART, PROFIBUS, FIELDBUS protocol)
- Power supply: 24V, 110V, 230V, 50Hz, 24Vdc (4 or 2 wires)
- Electronic housing: Rail mounting DIN 46277 IP40
- Version EEx ia IIC T6 2 wires available

Construction. Series LC30, 31 / LCM11, 12 / LE70, 71 / LEM70, 71

N°	Part Name	Materials		
		LC/LE.../INOX	LC/LE.../PVC	LC/LE.../PTFE
1	Enclosure*	Plastic/Aluminium	Plastic/Aluminium	Plastic/Aluminium
2	Connection	EN 1.4404 (SS 316L)	PVC	PTFE
3	Guide/Tube	EN 1.4404 (SS 316L)	PVC	PTFE
4	Float	EN 1.4404 (SS 316L)	PVC	PTFE
5	Magnet	Alnico	Alnico	Alnico
6	Contact/Reed chain	Reed	Reed	Reed
7	Float Stop	EN 1.4404 (SS 316L)	PVC	PTFE

* Normally connector DIN 43650 A

Dimensions for Level Switch/Level Transmitter

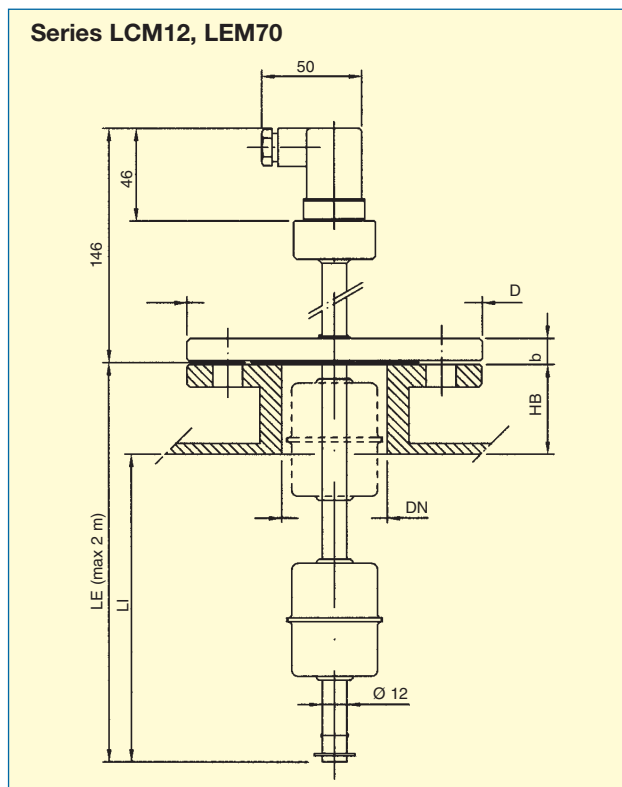
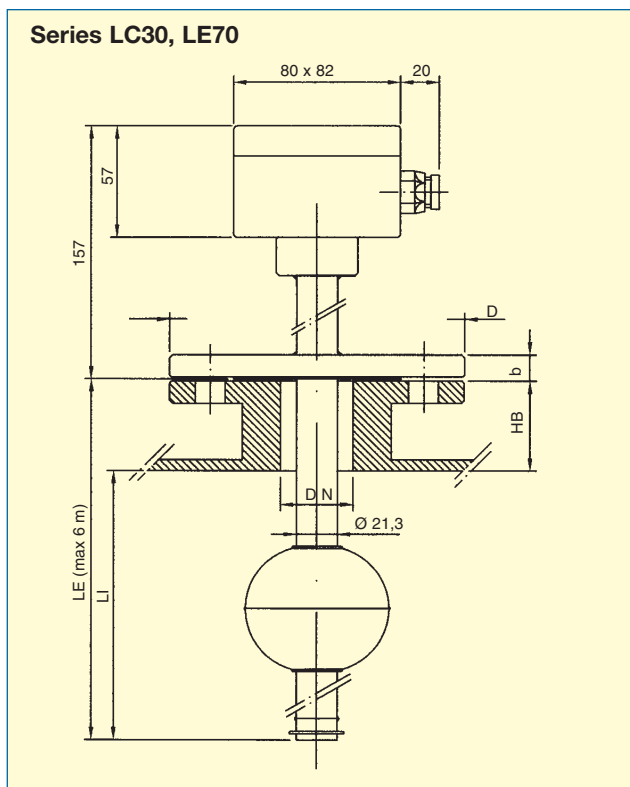

Assembly with EN 1092-1 PN16 Flanges

LC30, LE70, LCM12, LEM70

DN	PN	D	g	k	1xn ^o	b	A	B	HB	LE	LI
25	40	115	68	85	14x4	18	160	125	Related to the range. (Page 2,3)		
40 ¹	40	150	88	110	18x4	18	160	125			
100	16	220	158	180	18x8	20	160	125			
150	16	285	212	240	23x8	22	160	125			

(1) Normalized LC30, LCM12, LE70

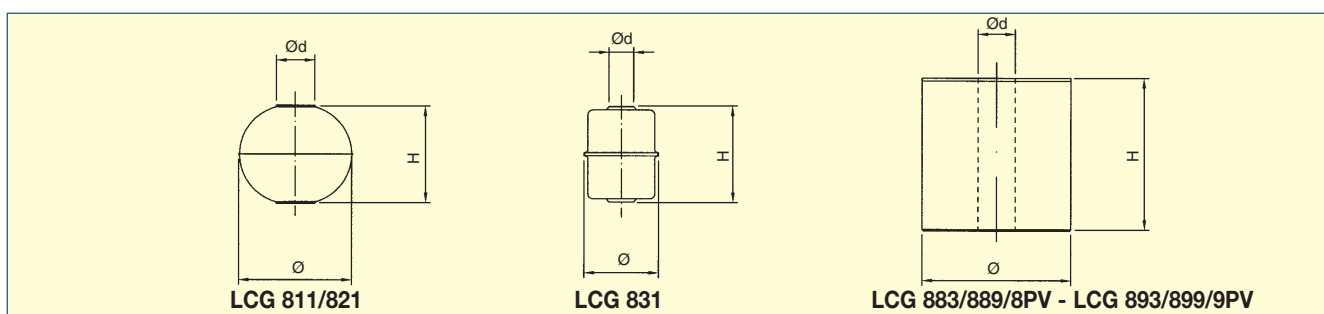

Float Characteristics

Model	LCG811	LCG821	LCG831	LCG883 ...	LCG889 ...	8PV	LCG893 ...	899 ...	9PV
Material	EN 1.4404 (SS 316L)	EN 1.4404 (SS 316L)	EN 1.4404 (SS 316L)	PVC	PP	PVDF	PVC	PP	PVDF
Max. Pressure	25	25	25	10	10	10	10	10	10
Min Density (kg/l)	0,650	0,600	0,800	0,800	0,700	0,800	0,800	0,700	0,800
Max Temp.	150°C	150°C	150°C	45°C	90°C	135°C	45°C	90°C	135°C
Ø mm	95,5	52	44,50	45	45	45	63	63	63
H mm	92	52	64	70	70	70	90	90	90
Ø d mm	26	13,6*	13,6*	17*	17*	17*	26,5	26,5	26,5

On request, other float designs and materials for different working conditions are available.

* Floats available only for Series LCM12, LEM70 pipe Ø 12 mm.

Dimensions for Level Switch/Level Transmitter

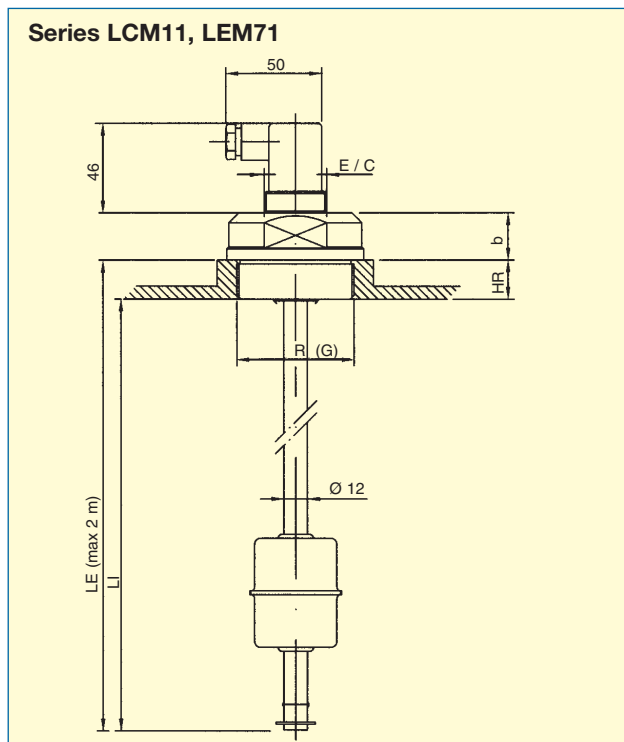
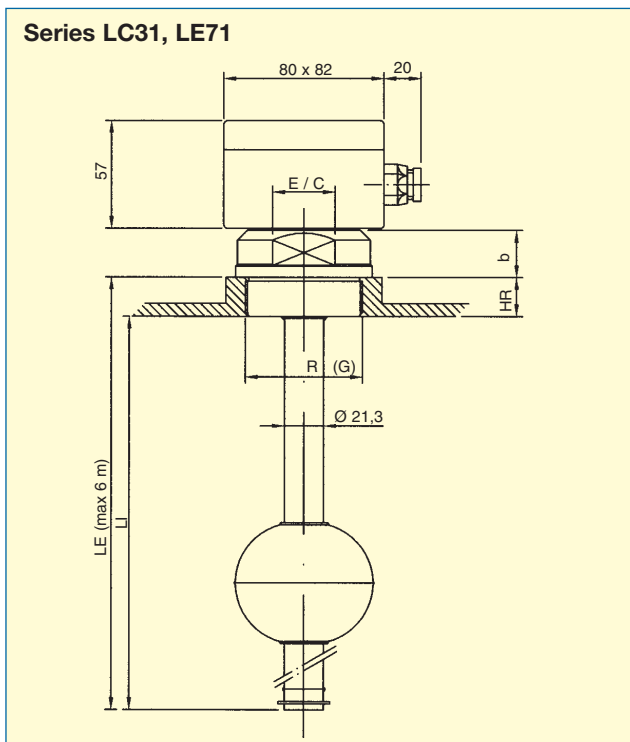

Assembly with Connection BSP/NPT LC31, LE71, LCM11, LEM71

R (G)	EC	b	HR	LE	LI
G 1 1/2"	60	22	16	Related to range	
G 2"	60	22	16	Page (2,3)	

Other sizes and standards on request.

Series LE70/71 y LEM70/71

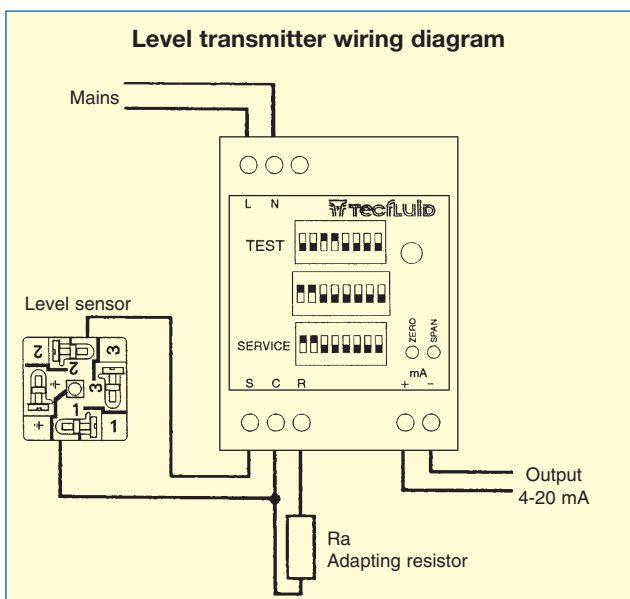
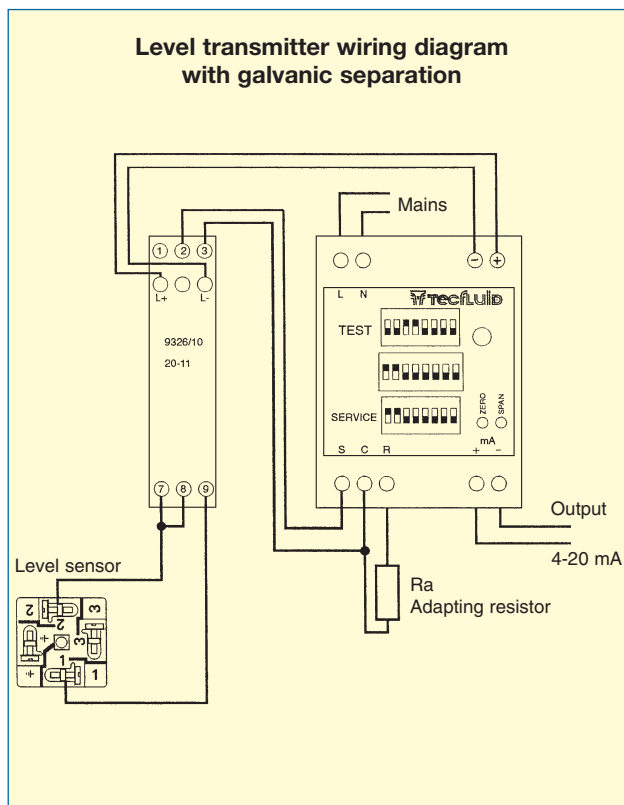

The adapting resistor value should be ten times the resistance of the level sensor at minimum level. Normally the level sensors have a resistance of 1000 ohms/meter and a 2,5 meter long level sensor would have an adapting resistor of 25kΩ. On demand communication with HART, Profibus or Fieldbus protocol.

Resistance/Current Converter Model TR420 0...4-20mA

The electronics TR420 convert the resistance to a 0...4-20 mA output signal proportional to the level. This signal can be connected to a local indicator, recorder or control system. Made up of bi-stable reed switches and resistors, assembled on a PCB to form a "chain" inside the guide tube. The electronics are mounted in a plastic enclosure suitable for mounting on a flat panel or rail according to DIN 46277.

Converter Technical Data

- Power supply: 110, 230, 240, 24 V ac 50/60 Hz
24 V dc
- Power consumption: < 1 VA
- Precision: 0,1%
- Working temperature: 0°C...+60°C
- Electrical connection: 4 wires (supply and output)
2 wires (supply and output)



Electric Transmitter (Mounting in rail DIN 46277)

Information for order

TR420 / a / vv

a	=	Output
= A		0 - 20 mA
= B		4 - 20 mA
= D		0 - 5 V dc
= E		0 - 10 V dc
= F		1 - 5 V dc
= G		2 - 10 V dc

vv	=	Power supply
= 110		110 V ac 50/60 Hz
= 220		220-230 V ac 50/60 Hz
= 240		240 V ac 50/60 Hz
= 024		24 V ac 50/60 Hz
= 24d		24 V dc

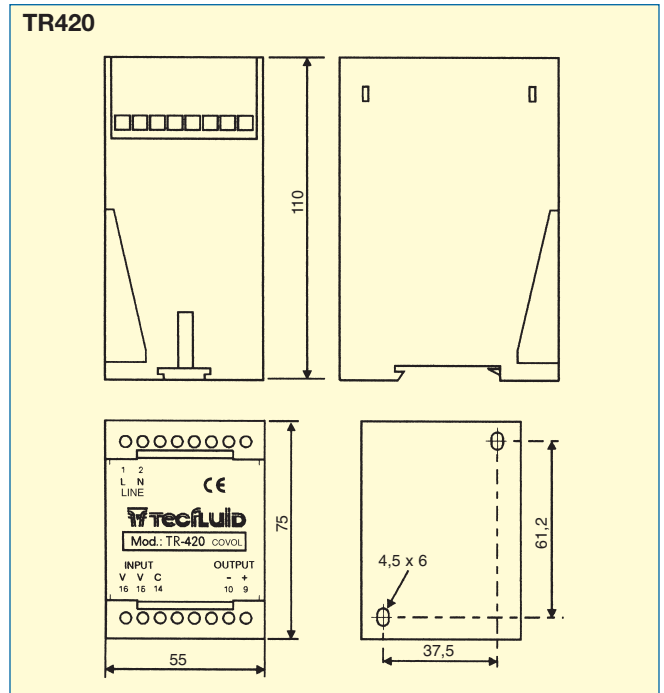

We are at your service, please consult us.
TECFLUID develops and manufactures instruments for gases and liquids, using the most advanced techniques.
Request information by telephone nº: +34 93 372 45 11