

WALL OR TON CONTAINER MOUNTED CHLORINATORS (SULFONATORS & AMMONIATORS)

The Series 70C1730 Chlorinators are versatile high quality, low cost solution feed units which are vacuum operated at sonic conditions. Proven design, rugged construction and use of the best available materials assure precise gas feeding, low maintenance, dependable operation and long life.

The chlorinator vacuum regulator mounts on a wall, or directly on the gas valve of a ton container by means of a yoke clamp connection. The chlorine flowmeter assembly may be mounted either on the side of the vacuum regulator or on the wall, at the user's convenience. The ejector may be used for systems having back pressures up to 200 psig (1380 kPa) and is usually wall mounted. It can be pipeline mounted with a 100 lb./day capacity limit.

Automatic changeover systems use two vacuum regulators without the necessity of a separate changeover valve. Multiple meter systems are available for feeding more than one point of application. The Series 70C1730 chlorinators are available for manual or start-stop operation and have maximum feed rates ranging from 1 to 500 lb./day (20 g/h to 10 kg/h). Similar units may be used for feeding ammonia, carbon dioxide and sulfur dioxide gases. The maximum capacities for these feeders are approximately 50%, 75% and 100% respectively of the chlorinator capacity, e.g., the ammonia feeder is rated at 250 lb/day maximum.

Design Features

- **Modern Design:** Sonic flow differential pressure control requires no moving parts resulting in increased life expectancy and dependability.
- **Versatility:** Optional second vacuum regulator adapts the feeder to automatic changeover without an extra valve. Additional flowmeters and ejectors allow for multipoint application.
- **Vacuum Operation:** Provides safety for operating personnel and equipment. Any leak will cause air to enter the system rather than gas to escape from it.
- **Minimum Maintenance:** Cartridge filtration system reduces routine inspections and maintenance time. Superior design of the high pressure ejector with triple back flow protection prevents the back flow of water to the vacuum regulator.

Engineering Specifications

Capacities: Standard metering tubes are available with the following maximum capacities: 1, 3, 10, 25, 50, 100, 200, 300 and 500 lb./day (20, 60, 200 and 500 g/h; 1, 2, 4, 6 and 10 kg/h) of chlorine gas. Any combination of capacities may be used on multiple metering tube units as long as the total does not exceed 500 lb./day (10 kg/h).

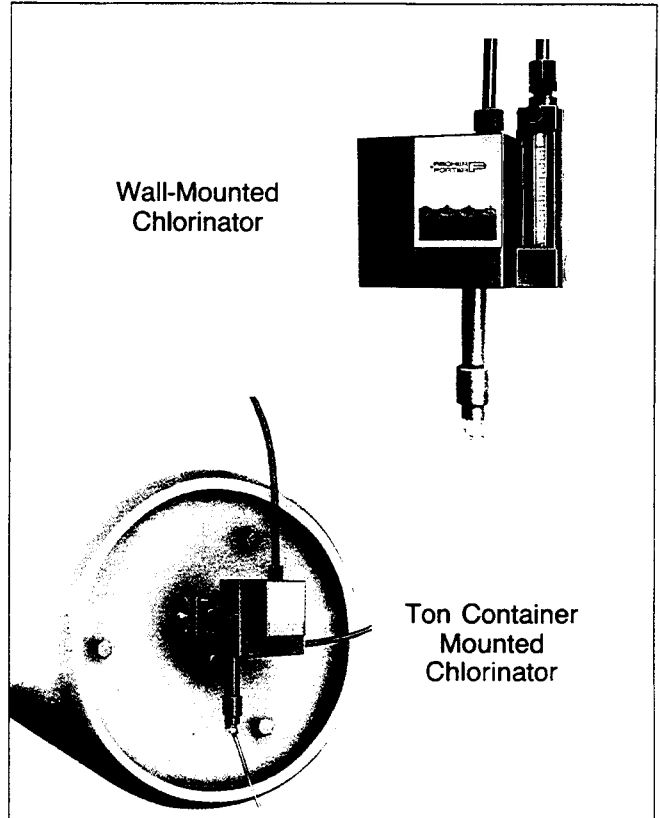

Flowmeter Rangeability: 20 to 1 for any one metering tube. For example, a chlorinator with a maximum capacity of 500 lb./day can measure and control gas feed over the range from 25 to 500 lb./day. Metering tube scale length is 4 inches (100 mm) for easy readability and is protected from accidental breakage by a plastic shield.

Ejector Requirements: Reasonably clean water at pressures of 3 psig (20 kPa) or greater is required to operate the ejector. Water consumption and required inlet pressure are dependent upon chlorinator capacity and ejector discharge pressure (back pressure). Refer to ejector sizing tables (available upon request) for details. (Also see Sizing Diskette below.) An ejector is normally required for each metering tube and rate valve. For swimming pool applications, the ejector with the integral anti-siphon valve must be used. The standard ejector is not suitable for alkaline solutions. For this service a special ejector is provided.

Sizing Diskette

An easy to use sizing diskette for chlorinator ejectors is available from Fischer & Porter Co. Please contact your nearest sales office.

Mounting: The chlorinator vacuum regulator with manifold is mounted on a wall or on the gas valve of a ton container. Temperature limits on the vacuum regulator are 2° to 54° C (35° to 130°F). The metering tube assembly may be mounted either on the side of the vacuum regulator or on a wall. The ejector may be wall or pipeline mounted for up to 100 lb/day capacity. If high temperature water is used (above 25°C, 77°F) ejector performance will be impaired due to decreased solubility of the gas and reference should be made to Technical Information Bulletin 71-3 for decreased pressure ratings of PVC piping.

Control Modes: Manual adjustment of the rate valve alters feed rate. On multiple meter chlorinators each meter is equipped with a rate valve. Start-stop control is obtained by installation of an automatic valve in the ejector supply line.

This valve, controlled by a timer, flow, pressure or pump control device, will start or stop the chlorinator. These chlorinators may be used for multiple or additive rate feed applications through the use of multiple meters and gas or water supply solenoid valves.

Connections

Chlorine Gas Inlet: ¾-inch NPT

Ejector Water Inlet: 1-inch NPT

Solution Outlet: ¾-inch NPT and 1-inch hose or 1½-inch NPT and 2-inch hose. Size is determined by water flow required to operate chlorinator. Alternate 1-inch NPT thread may be used for in-line ejector mounting. This alternate is usually reserved for 100 lb/day max. capacity.

Safety Vent: 5/8-inch tubing

Electrical Requirements: 120 V ac to operate a 30 watt electrical heater in the gas inlet. The heater is furnished with a 10 foot (3 m) cord having a plug with parallel blades and a round grounding pin.

Description of Operation

The chlorine gas from the cylinders or containers enters the manifold, where it is filtered and electrically heated to evaporate liquid chlorine which may be present. Water flowing through the ejector creates a vacuum which opens the inlet valve to admit the gas into the regulator. A diaphragm regulates the vacuum at this point to a closely controlled value.

The gas passes through the flowmeter(s) and the rate control valve(s) and then to the ejector or ejectors where it is thoroughly mixed and dissolved in the water and carried to the application point as a solution. When multiple metering tubes and ejectors are used, each operates independently of the others. Adjustment of one of the gas flow rates has no effect on the other rates.

The system is completely under vacuum from the ejector to the gas inlet valve during operation. If the water supply to the ejector is stopped, or the operating vacuum is lost for any other reason, the spring loaded gas inlet valve immediately closes to isolate the chlorinator from the gas supply. Any gas, under pressure, which might enter the regulator is vented from the system through the built-in pressure relief valve. If the source of chlorine gas is exhausted,

Materials of Construction: Cycolac™ Borg Warner Inc., Valox™ General Electric Co., PVC, Silver, Tantalum, Viton™ E.I. Du Pont Co., Hastelloy C-276™ Cabot Corp., Teflon™ E.I. Du Pont Co., KYNAR® Pennwalt Corp., transparent Polycarbonate, silver plated brass, and borosilicate glass are used in the construction of the chlorinator and ejector. The mounting manifold is ductile iron with a corrosion-resistant coating.

Temperature Limits: The corrosion resistant plastics used in the construction of the chlorinator will soften and distort above 130°F (54°C). The ambient temperature must not exceed this maximum allowable limit. Additionally, the temperature of the ejector supply water must not exceed 100°F (38°C).

Shipping Weight: Approximately 14 lb. (6.3 kg) including standard accessories.

Cubage: 3.4 ft³ (0.1 m³)

Accessories:

Standard

50 ft. (15 m) 5/8-inch tubing, 25 additional feet (7.5 m) are provided for automatic changeover systems and for each additional meter

Bottle for ammonia solution

Insect screen for vent line

Spare gaskets

Tube of thread lubricant

Universal wrench

Optional

Additional Flowmeters and Ejectors for Multiple Point Application

Amperometric Titrator (Specification 17T2000)

Automatic Changeover System

Booster Pumps

Chloralert™ Chlorine Gas Detector (Specification 17CA1000)

Diffusers

Flexible Connectors

Ejector with Integral Anti-siphon Valve (must be used for swimming pool applications)

Gas pressure gauge

Out-of-gas switch contact (rated at 4A at 120 or 240 V ac)

Vacuum Switches (excess and/or loss of vacuum)

a gas port closes to prevent excess vacuum levels from developing upstream of the vacuum regulator and also prevents any moisture from being drawn back into the operating components or the gas supply lines.

At the same time an indicator on the side of the vacuum regulator shows that the gas supply has been exhausted.

When the vacuum regulators are used in an automatic changeover system, either vacuum regulator is selected by the station operator allowing gas to flow until the chlorine source is exhausted. At that point the second vacuum regulator opens to allow gas feed to continue. Each regulator has an indicator to show whether it is in "Reserve", "Operating" or a "No gas" condition.

Within the ejector there are dual check valves and an emergency drain connection to protect the vacuum regulator from flooding.

DIMENSIONS

Vacuum Regulator

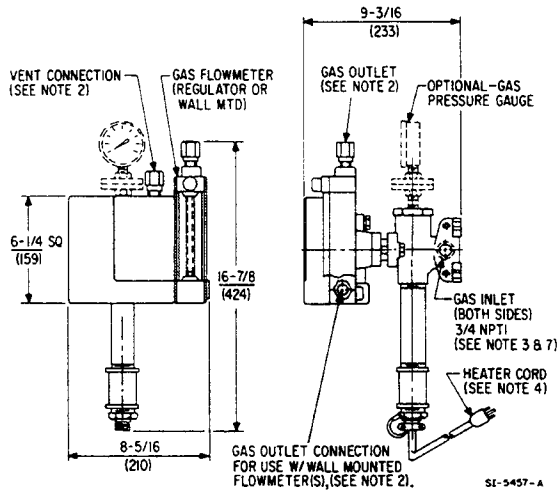

Flowmeter

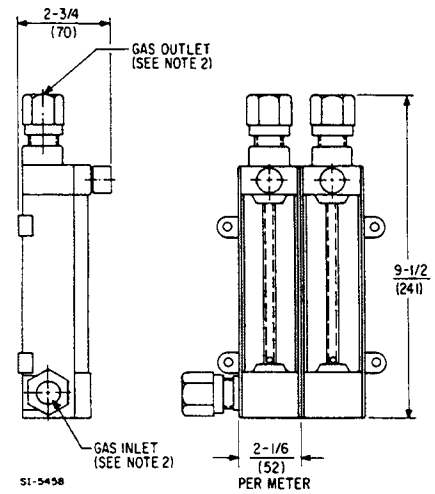

Ejector

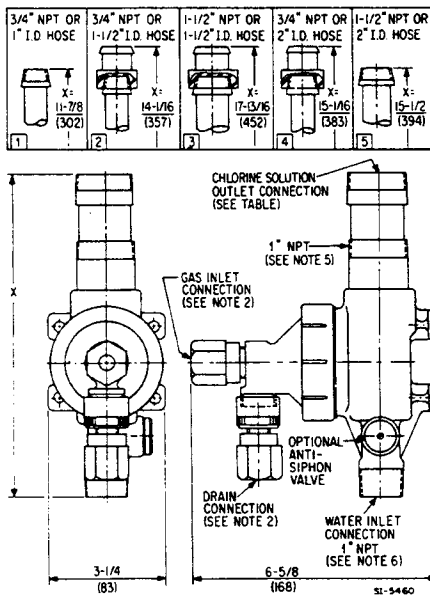

NOTES:

1. All dimensions are in inches (mm).
2. Adapter provided for 3/8 inch tubing.
3. One side provided with a plug. Other side provided with adapter for union nut coupling.
4. 10-foot long cord and three-pin plug.
5. For pipeline mounting of ejector. Limited to 100 lb/day max. and lines 6 inches in diameter or larger.
6. Water inlet piping normally should be no smaller than solution outlet size.
7. For ton container mounting, the manifold is attached to the ton container gas valve using a yoke connection provided with the chlorinator.
8. Special ejector supplied for alkaline service.

TYPICAL ARRANGEMENTS

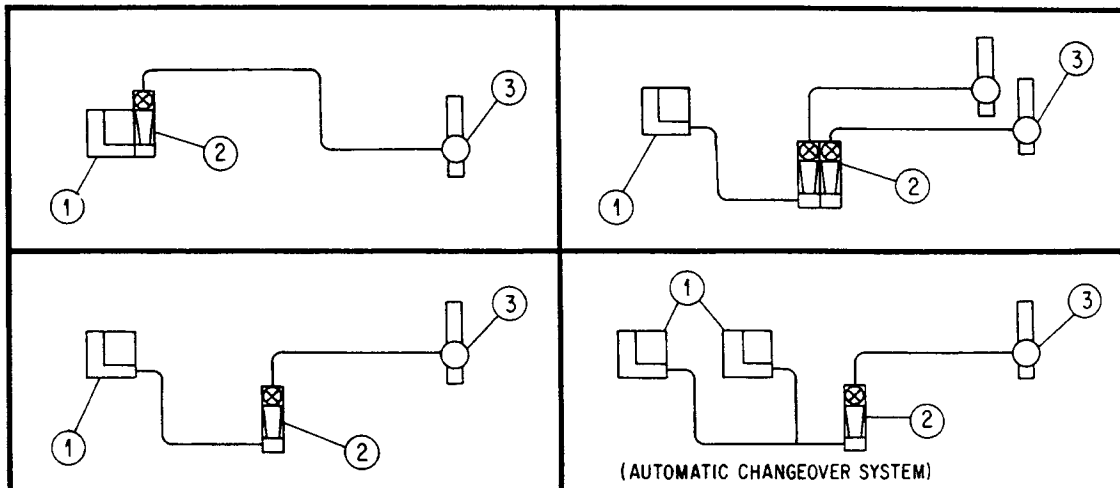

1. VACUUM REGULATOR 2. FLOWMETER AND RATE VALVE 3. EJECTOR SI-5462

MODEL NUMBER DESIGNATION

	70	17	X	D		X	X		
Chemical Service									
Ammonia _____	A								
Chlorine _____	C								
Sulfur Dioxide _____	S								
Carbon Dioxide _____	B								
Regulator Mounting and Type of Control									
Wall or Ton Container Mtd.									
w/Man. Control _____		3							
No. of Rate Values and Ejectors									
1 _____					11				
2 _____					22				
3 _____					33				
4 _____					44				
5 _____					55				
2nd Vac. Reg. for Auto Changeover									
Not Required _____						X			
Wall Mtd. _____							1		
Ton Container Mtd. _____								2	
Power Requirements									
120 V _____									1
240 V _____									2
Gas Pressure Gauge									
Not Required _____									X
Required _____									1
Units									
Metric _____									C
English _____									B

Ordering Information

Please specify the following:

- Model Number
- Ton container or wall mounted vacuum regulator
- Flowmeter Capacity (for each meter)
- Water supply and back pressure (for each ejector)
- Automatic Changeover (if required)
- Number of Flowmeters
- Number and Type of Ejectors
- Optional Accessories
- Maximum pH of ejector water supply

Equipment Description

The chlorinator shall be a vacuum operated solution feed type with a feed range of _____ to _____ lb/day of chlorine gas. A flowmeter having a 20:1 range shall be provided to indicate the chlorine feed rate. It shall be suitable for mounting on the wall or on the chlorinator vacuum regulator, protected by a plastic shield and equipped with a control valve for manual operation.

The unit shall be suitable for either ton container or wall mounting and include an interal manifold trap complete with a built-in electric heater with a ten foot cord. The manifold shall have a removable chlorine filter with a 5-square inch filtering area and 90 micron pore size.

A positive tight shut-off valve shall be provided within the chlorinator to isolate gas under pressure from the control system should there be a loss of vacuum. An easily removable filter screen shall be included upstream of the inlet valve. A spring-operated pressure relief valve shall be provided to prevent the build-up of pressure within the gas control system. An excess vacuum shut-off valve which isolates the regulator and gas supply system from the ejector on loss of gas pressure shall be supplied. Provision for automatic changeover shall be incorporated within the vacuum regulator without the need for an external valve. An indicator shall provide a visual signal when the chlorine gas supply is exhausted or interrupted.

The ejector shall be provided with dual check valves as well as an emergency drain valve to protect against flooding of the vacuum regulator.

The unit shall be supplied with the following accessories: 50 ft. of 5/8-inch polyethylene tubing for vent and vacuum lines, insect screen, bottle for ammonia solution, spare gaskets, thread lubricant, and a universal wrench. The chlorinator shall be Fischer & Porter Company Series 70C 1730.

Capital Controls Company, Inc.
 3000 Advance Lane, Colmar, PA 18915
 Tel: 215 997 4000, Fax 215 997 3779
 e-mail: marketing@capitalcontrols.com
 Web: <http://www.capitalcontrols.com>