



CAPITAL CONTROLS

Capital Controls developed the all-vacuum gas feeders which has become the worldwide standard. ADVANCE® Series 200 gas feeders are designed for manual or semi-automatic gas regulation. Automatic is a simple addition.

Easy to install, for indoor or outdoor installation, each 200 Series feeder is factory tested and needs no field adjustment prior to start-up. Ten different flowmeter capacities provide versatility in meeting gas flow requirements. Feeders mount directly on the gas valve of a cylinder, ton container or manifold utilizing a lead gasketed positive yoke clamp. Diaphragm ejectors are standard with a choice of diffuser outlets. As an option, a variety of different ejectors are available to meet your application needs.

A 200 Series gas feeder consists of a vacuum regulator, ejector or chemical induction unit and vacuum and vent tubing to make a complete system.

If multiple feed points are required, remote meter panels and additional ejectors are provided. A switchover module is offered to provide for uninterrupted service.

ADVANCE® Gas Feeder Series 200



- ◆ Safe and reliable all-vacuum operation
- ◆ Lifetime warranty on diaphragm and springs
- ◆ Worldwide standard for gas feeder technology
- ◆ Superior materials of construction for wet or dry gas service
- ◆ 3-year warranty
- ◆ Safe integral venting system
- ◆ Capacities up to 500 PPD (10 kg/h)
- ◆ Solid silver rate and inlet valves
- ◆ Accurate gas metering of:
 - Chlorine
 - Sulfur Dioxide
 - Ammonia
 - Carbon Dioxide
- ◆ Versatile mounting: direct cylinder, manifold or ton container
- ◆ Switchover capability with automatic reset for uninterrupted

Applications

For process water, waste treatment and water treatment in the municipal or industrial marketplace

- ◆ **Disinfection: potable water, municipal wastewater**
- ◆ **Chloramination: potable water**
- ◆ **Dechlorination: textiles, wastewater effluent**
- ◆ **Slime and algae control: irrigation systems, cooling towers**
- ◆ **Process water: chemical and pharmaceutical manufacture, food (washdown, canning, bleaching, taste and odor control)**
- ◆ **Cyanide, chromium removal: metal finishing wastes**
- ◆ **Zebra mussel control**
- ◆ **Process water: chemical and pharmaceutical manufacture, food (washdown, canning, bleaching, taste and odor control)**
- ◆ **Cyanide, chromium removal: metal finishing wastes**
- ◆ **Zebra mussel control**

Chemical Induction Units

Capital Controls CHLOR-A-VAC® Series 1420 chemical induction units offer improved chlorination and dechlorination through the high-efficiency mixing of gaseous chemical with process water. (Refer to Bulletin 130.0001)

Design Features

- ◆ **Sonic Flow:** Gas flows at sonic velocity maintaining constant gas flow; additional pressure regulation is not required.
- ◆ **Automatic Switchover:** A separate, independent device that does not require manual reset. Flow indication is available at both vacuum regulators. Each vacuum regulator has a separate independent vent and an integral pressure relief device.
- ◆ **Versatility:** Cylinder, manifold or ton container mounting. Unit can be modified for semi-automatic or automatic control. Variety of ejectors available for all applications.
- ◆ **Reliable:** Over 35 years of experience with all vacuum operation, loss of chlorine supply indicator, integral venting system, double-thickness main regulating diaphragm, lifetime warranty on diaphragm and springs, integral gas flow indicator.
- ◆ **Ease of maintenance:** Simplicity of design and modularized components; such as the replaceable inlet capsule for minimized maintenance.
- ◆ **Superior materials of construction:** Solid silver rate valve, monel drip leg for ton mounting, corrosion resistant yoke assembly, tantalum springs

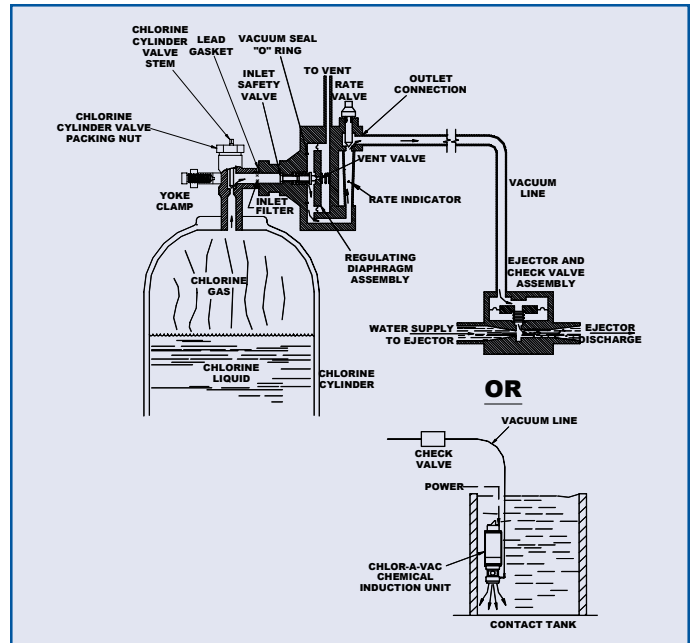

Figure 1 - Cylinder Mounted Flow Diagram

Operation

Water flowing through the ejector venturi, creates a vacuum which opens the check valve in the ejector. The vacuum is carried through the vacuum line to the vacuum regulator where the differential pressure causes the inlet valve at the vacuum regulator to open, initiating gas flow. A spring opposed diaphragm in the vacuum regulator, regulates the vacuum. The gas passes under vacuum through the flowmeter, the rate control valve, the vacuum line and to the ejector. Here the gas is thoroughly mixed with water and applied as a solution. (Figure 1)

The system is completely under vacuum from each ejector to the vacuum regulator inlet safety valve. If the water supply to any ejector stops or vacuum is lost for any other reason, the spring loaded inlet valve immediately closes and isolates the gas supply. If the gas source depletes the unit seals to prevent moisture from being drawn back into the gas source. When more than one feed point is desired multiple flowmeters and ejectors can be supplied.

For uninterrupted gas feeding on a round-the-clock basis, an automatic switchover system is required. Each system consists of two vacuum regulators, one vacuum type automatic switchover module, one ejector and one remote meter panel. An automatic switchover module allows gas to flow under vacuum from the regulator in service through the switchover module to the remote meter panel and the ejector, until that source is depleted. The vacuum sealing valve on the regulator then closes and the vacuum level in the system increases, initiating the spring-loaded toggle assembly in the switchover module. (Figure 2) The open valve on the depleted source closes while the valve on the standby source opens to permit gas flow. When a fresh gas supply replaces the depleted source it will automatically be placed in standby. The fresh supply will not be accessed until the supply in service is exhausted.

GAS FLOWMETER DATA

100 PPD (2 kg/h)	250 PPD (5 kg/h)	500 PPD (10 kg/h)
3" (76 mm) length	3" (76 mm) length	6" (152 mm) length
0.6 PPD/11 g/h 1.5 PPD/28 g/h 4 PPD/75 g/h 10 PPD/200 g/h 25 PPD/0.5 kg/h 50 PPD/1 kg/h 100 PPD/2 kg/h	25 PPD/0.5 kg/h 50 PPD/1 kg/h 100 PPD/2 kg/h 200 PPD/4 kg/h 250 PPD/5 kg/h	25 PPD/0.5 kg/h 50 PPD/1 kg/h 100 PPD/2 kg/h 200 PPD/4 kg/h 500 PPD/10 kg/h

TUBING

Connection Size

Maximum Capacity	Vacuum	Vent
100 PPD (2 kg/h)	3/8"	3/8"
250 PPD (5 kg/h)	1/2"	3/8"
500 PPD (10 kg/h)	5/8"	3/8"

Vacuum Tubing Size Requirements

Maximum Feed Rate	Length Of Vacuum Tubing		
	100 feet (31 meters)	200 feet (61 meters)	500 feet (153 meters)
50 PPD (1 kg/h)	3/8"	3/8"	1/2"
100 PPD (2 kg/h)	3/8"	1/2"	1/2"
250 PPD (5 kg/h)	1/2"	5/8"	3/4"
500 PPD (10 kg/h)	5/8"	3/4"	1"

WEIGHTS & DIMENSIONS

Dimensions: Inches [Millimeters]

Vacuum Regulator:

Cylinder Mounted:

100-250 PPD (2-5 kg/h): 5 7/8 [149] L X 5 7/8 [149] H X 7 3/4 [196] H

500 PPD (10 kg/h): 5 7/8 [149] L X 10 3/8 [263] H X 8 3/8 [214] W

Ton Mounted:

100-250 PPD (2-5 kg/h): 5 7/8 [149] L X 15 15/16 [405] H X 8 13/16 [224] W

500 PPD (10 kg/h): 5 7/8 [149] L X 18 1/4 [464] H X 9 1/2 [241] W

Switchover Module: 7 5/8 [195] L X 6 [150] H X 2 3/4 [70] W

Remote Meter:

100-250 PPD (2-5 kg/h): 2 [51] L X 5 13/16 [148] H X 2 [51] W

500 PPD (10 kg/h): 5 [127] L X 11 3/4 [298] H X 2 [51] W

Ejector:

100-250 PPD (2-5 kg/h): 2 5/8 [70] L X 3 1/4 [80] H X 2 5/8 [70] W

500 PPD (10 kg/h): 4 1/4 [110] L X 3 1/4 [80] H X 4 1/4 [110] W

Shipping Weight:

Vacuum Regulator:

Cylinder Mounted 8 lbs (3.6 kgs)

Ton Mounted: 17 lbs (7.7 kgs)

Switchover Module: 2 lbs (0.9 kgs)

Remote Meter: 1 lb (0.5 kg)

Ejector: 3 lbs (1.4 kgs)

Technical Data

ADVANCE® Gas Feeder

GENERAL

Capacities: Standard dual-rate indicating flowmeters are available with the following capacities: 0.6, 1.5, 4, 10, 25, 50, 100, 200, 250, 500 PPD (11, 28, 75, 200 g/h, 0.5, 1, 2, 4, 5, 10 kg/h) of chlorine gas. To determine feed rates for other gases, multiply each chlorine value by:

0.95 for sulfur dioxide

0.50 for ammonia

0.78 for carbon dioxide

Maximum Allowable Inlet Pressure: 300 psig (20.7 bar)

Maximum Recommended Inlet Pressure: 150 psig (10.3 bar)

Maximum Temperature: 140°F (60°C)

Minimum Temperature: 40°F (4.4°C)

Minimum Recommended Inlet Pressure: 20 psig (1.4 bar)

Operating Vacuum Level: 20" of water column (minimum)

Vent Pressure Relief Setting:

up to 500 PPD (10 kg/h): 14" to 15" water column

over 500 PPD (10 kg/h): 3.5" to 4" water column

Flowmeter: The minimum feed capacity for every gas flowmeter is 1/20th of the maximum capacity. Accuracy is within ±4% of maximum flowmeter capacity.

Electrical Requirements: On ton mounted units the drip leg is provided with a 120/240 Vac, 50/60 Hz, single phase heater.

EJECTOR CONNECTIONS

Maximum Capacity	Standard	Optional*
100 PPD (2 kg/h)	Inlet: 1" I.D. hose	3/4PT, 3/4" hose
	Outlet: Universal diffuser for 3/4" NPT male thread, spray or open end or 1" I.D. hose	3/4" I.D. hose, 1" male pipe, 3/4" open end diffuser, 10" long corporation stop
250 & 500 PPD (5 & 10 kg/h)	Inlet: 1 1/4" NPT	1 1/2" hose
	Outlet: 1 1/2" hose	1 1/4" NPT

* Optional inlets and outlets require special consideration to ensure that pressure losses are not excessive. Optional Diaframless™ and Anti-Siphon ejectors are available

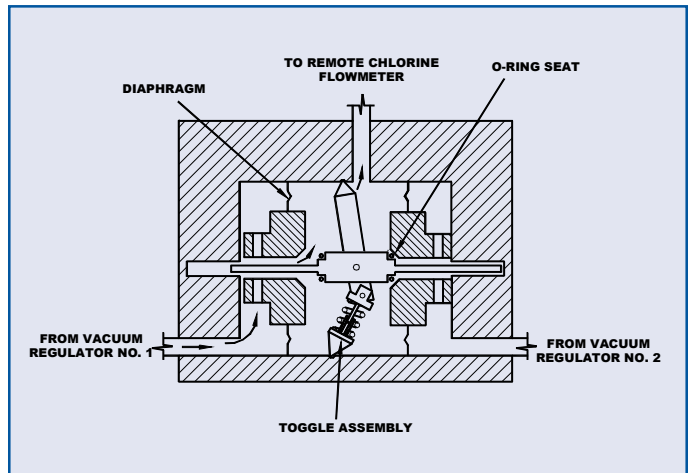

Figure 2 - Automatic Switchover Flow Diagram

Warranty and Capability

Capital Controls offers a lifetime warranty on the diaphragm and springs. There is a three (3) year limited warranty on ADVANCE® 200 Series equipment.

Capital Controls is ISO 9001 certified to provide quality and precision materials. Disinfection technologies, water quality monitors and instrumentation for water and wastewater are areas of specialization. Over 35 years of industrial and municipal application experience in the water and wastewater industries is incorporated into the equipment design to provide high quality comprehensive solutions for the global market.

Brief Specification

The gas feeder design shall be of the vacuum operated, solution feed type. The gas feeder shall be constructed of materials suitable for wet or dry gas service. All springs used in the vacuum regulator shall be of tantalum alloy (stainless steel for ammonia). The rate valve and seat shall be solid silver (stainless steel for ammonia). A double-thickness diaphragm shall be provided for vacuum regulation. The rate of gas feed shall be set manually and shall remain constant until manually changed. The gas shall flow at sonic velocity and a differential pressure regulator shall not be required.

The system shall be convertible to automatic control by insertion of a motorized control valve in the vacuum line to receive a signal from the appropriate control equipment.

The vacuum regulator shall mount directly on the container valve by means of a corrosion resistant yoke assembly. A spring-opposed inlet valve shall close tight upon loss of vacuum. Each vacuum regulator shall be equipped with a loss-of-gas indicator, and a gas flowmeter. A spring-loaded diaphragm actuated pressure relief valve integral to the vacuum regulator shall be provided to relieve gas pressure. The inlet capsule shall be a complete module, installed without the use of any tools.

The vacuum producing device shall be an ejector with a spring-loaded check valve to prevent flooding of the vacuum regulator or a CHLOR-A-VAC® chemical induction unit, Series 1420.

Automatic switchover shall be provided with automatic reset and integrally mounted vacuum regulator flow indicator.

Design improvements may be made without notice.

Represented by:



CAPITAL CONTROLS

3000 Advance Lane Colmar, PA 18915

Tel: 215-997-4000 • Fax: 215-997-4062

Web: www.capitalcontrols.com

E-mail: marketing@capitalcontrols.com

- UNITED KINGDOM • UNITED STATES • HONG KONG
- INDIA • ITALY • MALAYSIA